

IF IN DOUBT EMAIL QUESTIONS TO ian@patto.com.au

ITEM No.	QTY.	DESCRIPTION	LENGTH	REMARKS	MASS
1	8	M 5 C/S Socket head machine bolts material equivalent to JIS B 1186 Bolt Spec.	10		

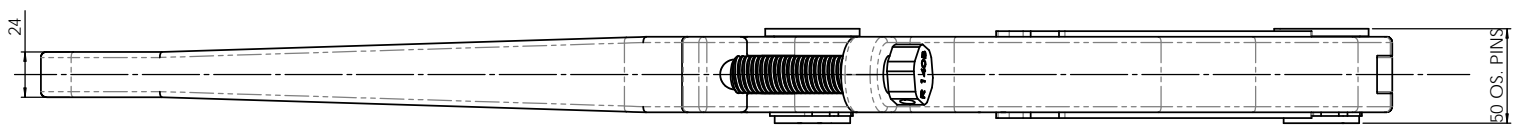

TOP VIEW

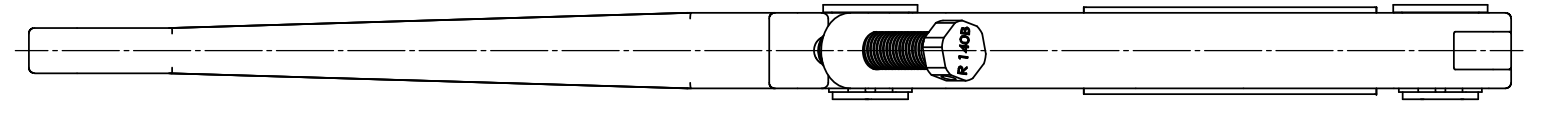

TOP VIEW

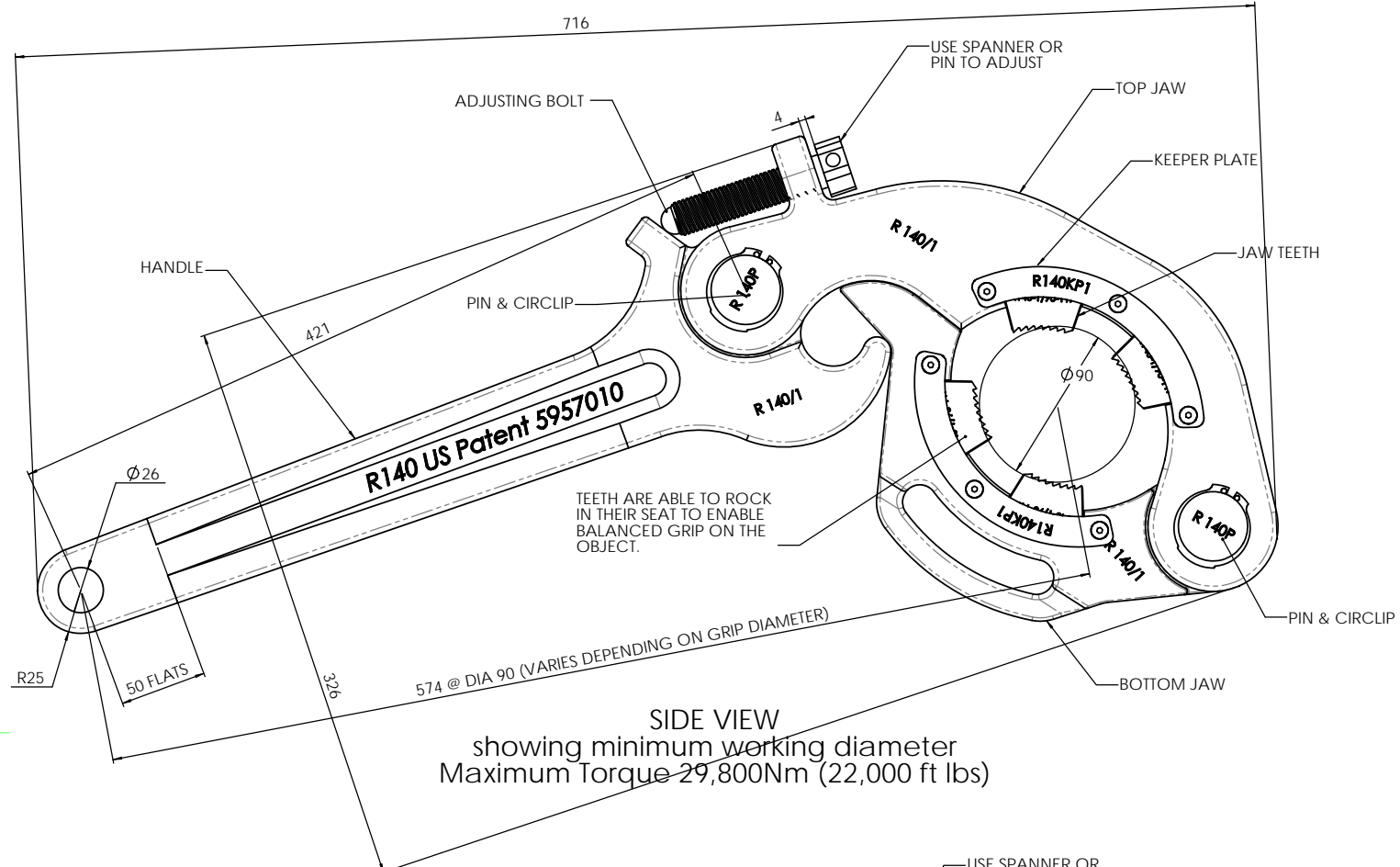

SIDE VIEW showing minimum working diameter
Maximum Torque 29,800Nm (22,000 ft lbs)

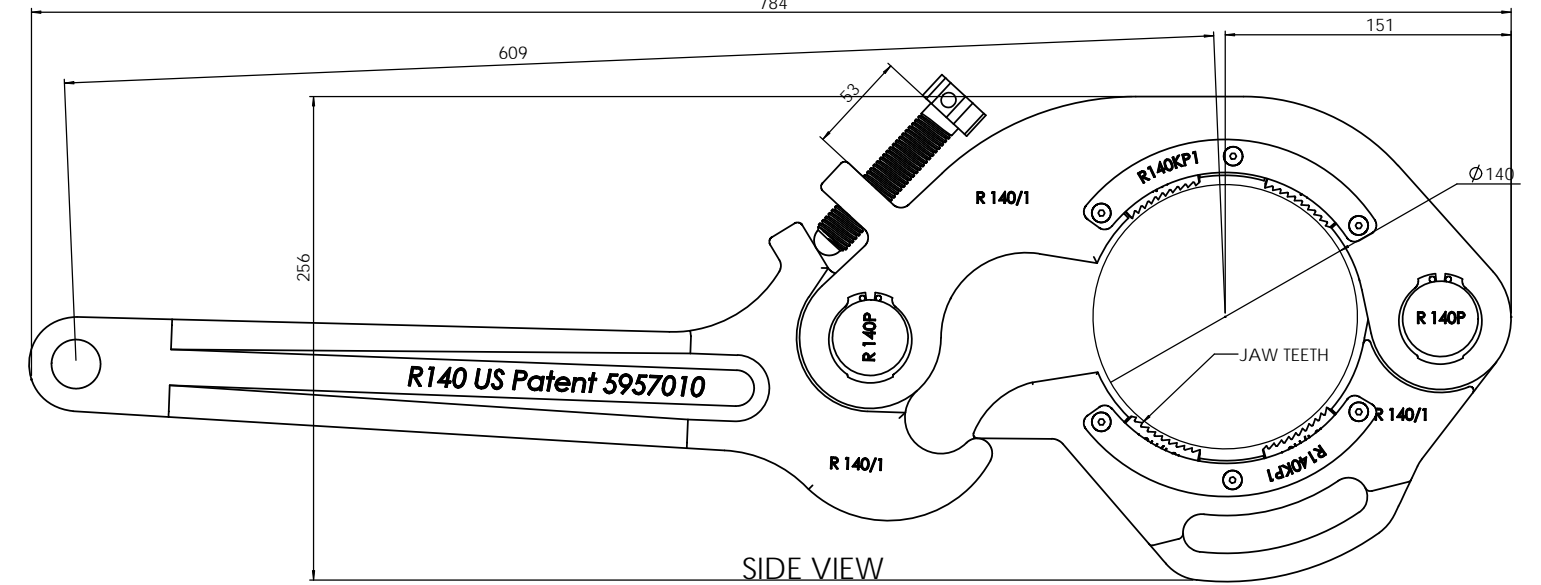

SIDE VIEW showing maximum working diameter

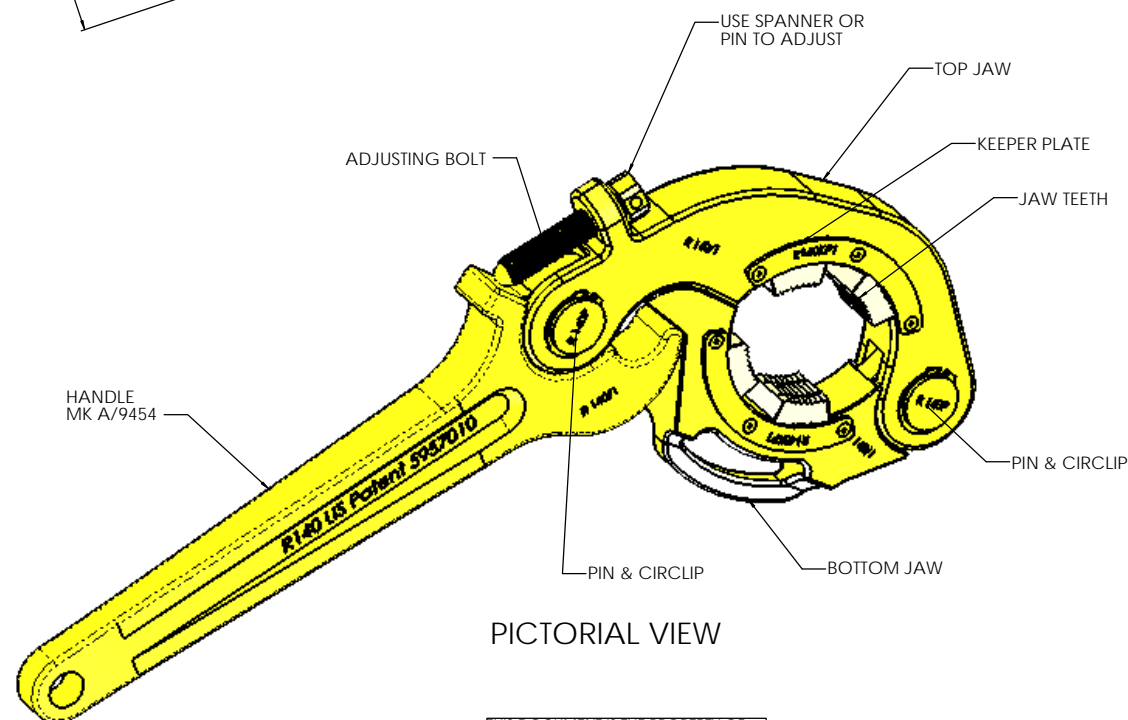

PICTORIAL VIEW

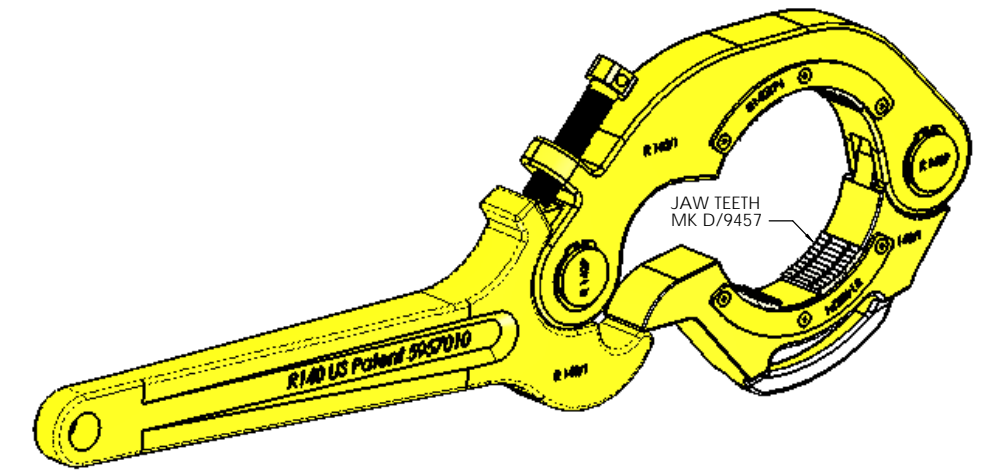

PICTORIAL VIEW

THIS DOCUMENT IS THE PROPERTY OF IAN PATTERSON & PARTNERS (I.P.P.) AND THE SUBJECT MATTER HEREIN IS PRIVATE & RESTRICTED. DO NOT USE, REPRODUCE, COPY OR DISCLOSE EXCEPT WITH AND ONLY TO THE EXTENT OF PRIOR WRITTEN CONSENT OF I.P.P. PERSONS RECEIVING THIS DOCUMENT ARE RESPONSIBLE FOR RESTRICTING DISCLOSURE EXCEPT AS ABSOLUTELY NECESSARY CONSISTENT WITH THE INTENDED USE. WHEN SUCH USE IS COMPLETED, RETURN IMMEDIATELY TO IAN PATTERSON & PARTNERS AT PO Box 5645 MMC Mackay Queensland Australia 4741.



No.	REVISION DESCRIPTION	REF.	DRAWN
1	Opposite side keeper plate now bolted & Specification drg IPP 9459 added		Patto
0	Issued for tender		Patto
B	Checked A.P., Notes added and issued for review		Patto
A	Issued for comment & review		Patto

REFERENCE DRAWINGS	DRG No
Complete Specification	IPP 9459.
Quality Control Schedule	IPP 9458.
Pins, Keepers, Teeth & Adjuster details.	IPP 9457.
Bottom Jaw details.	IPP 9456.
Top Jaw details.	IPP 9455.
Handle details.	IPP 9454.

IAN PATTERSON & PARTNERS
36 Davey St. Glenella Mackay Australia 4740
PH 61 7 4942 5502
FX 61 7 4942 5509

RAPSPAN TOOLS PTY LTD
R140 US Patent 5957010
ASSEMBLY

RAP-2005-004 3D IPP 9453					
DESIGN	DATE	CHECKED	DATE	REV	DATE
A.P.				A.	22-7-05
DRAWN	DATE	APPROVED	DATE	B.	28-7-05
PATTO.	22-7-05.			O.	24-8-05
DRG No.				1.	4-1-06
IPP 9453					